



SAM

CAMERA INSPECTION MOTORISEE PTZ CAMERA TV INSPECTION



** Suivi de process // Process control*

** Maintenance // Maintenance*

** Repérage // Spotting*

● Guidage // Guiding

Utilisation en eau & en air
Caméra à tube Zoom nucléaire : x6
1 Projecteur 200 Watts

//

Water and air operating
Tube camera with nuclear zoom X6
1 x 200 W adjustable



SAM

CAMERA INSPECTION MOTORISEE PTZ CAMERA TV INSPECTION

DESIGNATION	SAM
<i>Captteur //Sensor</i>	N & B 2/3 " VIDICON DURCI // Radiation tolerant Vidicon tube 2:3"
Résolution//Resolution	550 lignes TV:// TV lines
Rap S/B Ratio Signal /Noise	> 43 dB
Sensibilité//Sensitivity	2 Lux
Tenue aux radiations//Radiation tolerant	
Dose cumulée // Cumulated dose	1x10 ⁷ rads
Dose instantanée// Dose	1 x 10 ⁵ rads / heure// Hour
Objectif//Lens	Focale 12 à 72 mm (zoom x 6) Focal 12 to 72 mm (zoom x 6)
Eclairage //Lighting	1x 200 halogène// 1 x halogen 200 W
Motorisation Pan and Tilt	
Axe Site //Tilt axis	+/-140° , fins de course// Limited switch
Axe azimut//Pan axis	360°, fins de course// Limited switch
Connectique //Connector	JUPITER // Socket JUPITER waterproof
Etanchéité //Depth using	3 bars
Matière//Material	Inox 304L // Stainless steel 304L
Dimensions	Voir croquis // See draws
Poids // Weight	17 kg

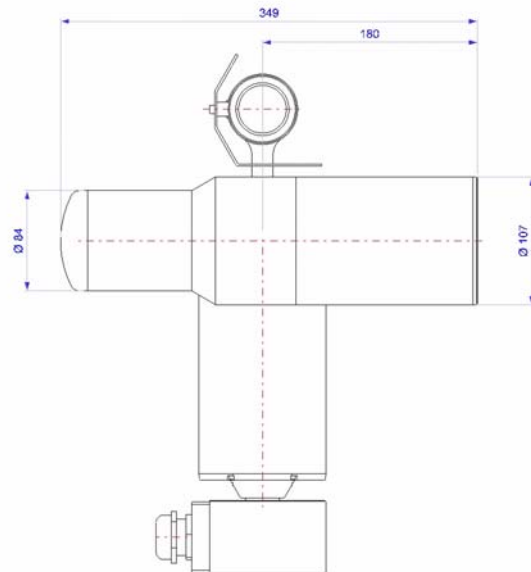
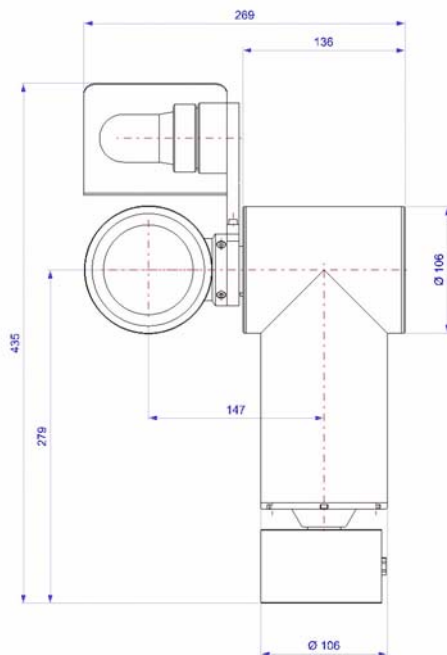

CYBERIA 55 Rue MERLOT 34130 MAUGUIO (France) Tel:+33(0)4.67.99.94.58 Fax:+33(0)4.67.99.94.59
[Http://www.cyberiasite.com](http://www.cyberiasite.com) Email: cyberiasite@orange.fr

