



LUXUS HLAE

PROJECTEUR AIR/EAU HAUTE PERFORMANCE LEDS *HIGH PERFORMANCE AIR WATER LIGHTING*

*Eclairage de grande puissance et homogène (ci-dessous résultat avec
1 seul projecteur HLAE//
High performance Lighting and homogenous(below result with only
one HLAE)*



**Utilisation AIR /EAU
70000 lumens durée de vie >50000H
Lumière Blanche >5600° K**

//

***AIR /WATER operating
70000 Lumens , lifetime >50000H
Light color temperature>5600 K***

CYBERIA 55 Rue MERLOT 34130 MAUGUIO (France) Tel:+33(0)4.67.99.94.58 Fax:+33(0)4.67.99.94.59

HTIP// www.cyberia-robotics.com

Email:info@cyberia-robotics.com





LUXUS HLAE

PROJECTEUR AIR/EAU HAUTE PERFORMANCE LEDS HIGH PERFORMANCE AIR WATER LIGHTING

PROJECTEUR // LIGHTING

DESIGNATION	CARACTERISTIQUES//TECHNICAL SPECIFICATIONS
Luminosité // <i>Light output</i>	70000 lumens ;20000 lux
Durée de vie // <i>Lifetime</i>	> 50000 HEURES:// > 50000 HOURS
Angle // <i>Beam</i>	115°
Température de couleur// <i>Ligh color temperature</i>	> 5600 k
Intensité réglable// <i>Adjustable lighting</i>	0-100%
Sécurité// <i>Security</i>	Mesure de température avec coupure à 90°C // <i>Temperature measurement with switch off at about 90°C</i>
Matière // <i>Material</i>	AUG4 // <i>AUG4 Anodized</i>
Etanchéité.// <i>Operating depth</i>	3 bars
Connectique // <i>Connector</i>	JUPITER 4 contacts ou sortie Presse étoupe // <i>JUPITER 4 PINS or GLOVE GLAND</i>
Inclinaison // <i>Tilt axis</i>	Réglable 0 à 60° // <i>Adjustable 0 to 60°</i>
Température utilisation en AIR EAU // <i>Operating temperature In Water</i>	-10° à 50°C // <i>-10° to 50 °C</i> <i>Pour température ambiante air 21° C Température dissipateur à 100% 61°C</i> <i>For 21°C air temperature 61°C at thermal radiator</i>
Dimensions	Voir ci-dessous // <i>See below</i>
Poids En air et eau // <i>Weight In Air and Water</i>	Air 29 Kg Eau 16.5 Kg <i>Air 29 Kg Water 16.5 Kg</i>

COFFRET DE COMMANDE // UNIT CONTROL

DESIGNATION	CARACTERISTIQUES//TECHNICAL SPECIFICATIONS
Alimentation// <i>Power supply</i>	110 -230 V 50-60 hz < 600 W
Dimensions (mm)	300 x 300 x 150
Poids // <i>Weigth</i>	10 kg

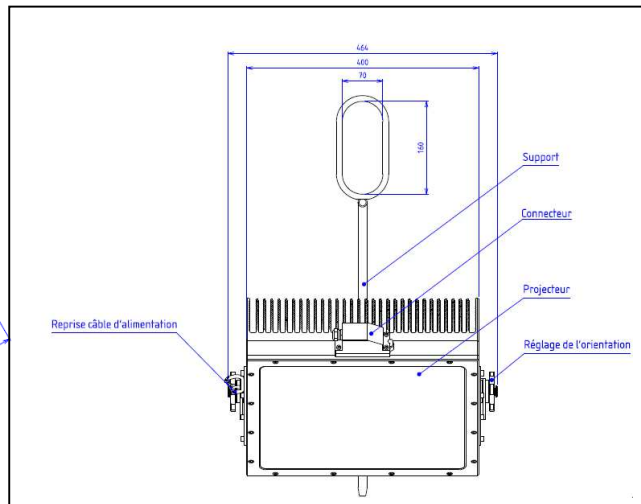
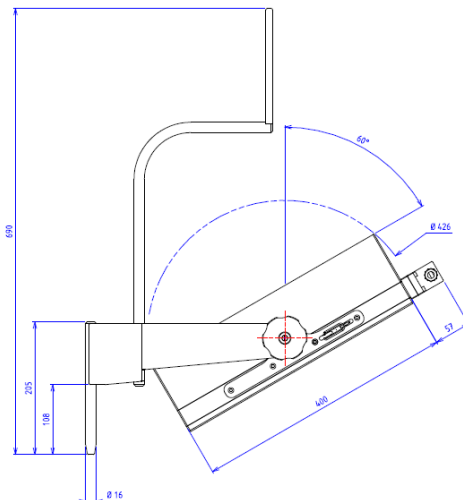

30 MAUGUIO (France) Tel:+33(0)4.67.99.94.58 Fax:+33(0)4.67.99.94.59

HTTP// www.cyberia-robotics.com

Email:info@cyberia-robotics.com

